

# **DMICDC - NSPCL**

**DMICDC Neemrana Solar Power Company Limited**

Invitation to Bid

**EPCWORKS ASSOCIATED WITH DECOMMISSIONING OF 1 MW SOLAR-DIESEL OFF-GRID POWER SUPPLY TO MIKUNI-INDIA PVT LTD & INSTALLATION AND COMMISSIONING OF 1 MW SOLAR FOR THIRD PARTY SALE TO TOYODA GOSEI MINDA INDIA PVT LTD**

**AT**

**NEEMRANA INDUSTRIAL PARK, JAPANESE ZONE, NEEMRANA, RAJASTHAN**

---

**REQUEST FOR QUALIFICATION**

**Cum**

**REQUEST FOR PROPOSAL**

---

**April 2020**

**DMICDC Neemrana Solar Power Company Limited  
(DMICDC - NSPCL)**

8<sup>th</sup> Floor, Jeevan Bharti Building, Tower-1,  
Connaught Place, New Delhi-110001  
Tel: +91 11 2611 3348  
Fax: +91 11 2611 3349

**NOTICE INVITING REQUEST FOR QUALIFICATION CUM REQUEST FOR PROPOSAL**

**DMICDC - NSPCL  
DMICDC Neemrana Solar Power Company Limited**

**INVITATION TO BID**

**REQUEST FOR QUALIFICATION CUM REQUEST FOR PROPOSAL FOR  
SELECTION OF CONTRACTOR FOR EPC WORKS RELATED TO  
DECOMMISSIONING OF 1 MW SOLAR-DIESEL OFF-GRID POWER SUPPLY  
TO MIKUNI-INDIA PVT LTD & INSTALLATION AND COMMISSIONING OF 1 MW  
SOLAR FOR THIRD PARTY SALE TO TOYODA GOSEI MINDA INDIA PVT LTD  
AT NEEMRANA INDUSTRIAL PARK,  
JAPANESE ZONE, NEEMRANA, RAJASTHAN**

**Date: April 20th, 2020**

DMICDC Neemrana Solar Power Company Limited (DMICDC-NSPCL) invites "Request for Qualification Cum Request for Proposal" (RFQ cum RFP) from interested bidders for carrying out All Works associated with Decommissioning of 1 MW Solar-Diesel Hybrid power supply to Mikuni India Pvt Ltd and Installation and commissioning of 1 MW Solar power on third party sale to Toyoda Gosei Mind India Pvt Ltd.

The bid processing fee is Rs. 1,180 and bid security (EMD) is Rs. 30,000.

**Interested bidders are requested to submit their responses to the Request for Qualification Cum Request for Proposal at the address mentioned below on or before May 11<sup>th</sup> 2020 by 3:00 PM.**

The submissions must be addressed to:

**DMICDC Neemrana Solar Power Company Limited**  
8<sup>th</sup> Floor, Jeevan Bharti Building, Tower-1,  
Connaught Place, New Delhi-110001

CIN: U40300DL2014PLC266439

**Disclaimer:**

1. This REQUEST FOR QUALIFICATION (herein after called as RFQ)cum REQUEST FOR PROPOSAL (herein after called as RFP) document is neither an agreement nor an offer by the DMICDC Neemrana Solar Power Company Limited (DMICDC- NSPCL) to the prospective Bidders or any other person. The purpose of this RFQ cum RFP is to provide information to the interested parties that may be useful to them in the formulation of their Bid pursuant to this RFQ cum RFP.
2. DMICDC - NSPCL does not make any representation or warranty as to the accuracy, reliability or completeness of the information in this RFQ cum RFP document and it is not possible for DMICDC - NSPCL to consider particular needs of each party who reads or uses this RFQ cum RFP document. This RFQ cum RFP includes statements which reflect various assumptions and assessments arrived at by DMICDC - NSPCL in relation to the Project. Such assumptions, assessments and statements do not purport to contain all the information that each Bidder may require. Each prospective Bidder should conduct its own investigations and analyses and check the accuracy, reliability and completeness of the information provided in this RFQ cum RFP document and obtain independent advice from appropriate sources.
3. DMICDC - NSPCL will not have any liability to any prospective Bidding Company / Firm / Consortium or any other person including natural and artificial under any laws (including without limitation the law of contract, tort), the principles of equity, restitution or unjust enrichment or otherwise for any loss, expense or damage which may arise from or be incurred or suffered in connection with anything contained in this RFQ cum RFP document, any matter deemed to form part of this RFQ cum RFP document, the award of the Project, the information and any other information supplied by or on behalf of DMICDC-NSPCL or their employees, any consultants or otherwise arising in any way from the selection process for the Project. DMICDC-NSPCL will also not be liable in any manner whether resulting from negligence or otherwise however caused arising from reliance of any Bidder upon any statements contained in this RFQ cum RFP.
4. DMICDC-NSPCL will not be responsible for any delay in receiving the Bids. The issue of this RFQ cum RFP does not imply that DMICDC-NSPCL is bound to select the Bidder or to appoint the Selected Bidder, as the case may be, for the Project and DMICDC-NSPCL reserves all the right and have discretionary powers to accept/reject any or all of Bids submitted in response to this RFQ cum RFP document at any stage without assigning any reasons and without any justification. DMICDC - NSPCL also reserves the right to withhold or withdraw the process at any stage with intimation to all who submitted the RFQ cum RFP document.
5. The information given is not an exhaustive account of statutory requirements and should not be regarded as a complete or authoritative statement of law. DMICDC - NSPCL accepts no

responsibility for the accuracy or otherwise for any interpretation or opinion on the law expressed herein.

6. DMICDC - NSPCL reserves all the rights and power to change / modify / amend any or all provisions of this RFQ cum RFP document. Such revisions to the RFQ cum RFP / amended RFQ cum RFP will be made available on the website of DMICDC - NSPCL.

## TABLE OF CONTENTS

SECTION 1	:	Letter Of Invitation	6
SECTION 2	:	Instruction to Bidders	7
SECTION 3	:	Qualification & Technical Requirements	15
		Of Bid – Standard Forms	
SECTION 4	:	Financial Proposal – Standard Forms	20
SECTION 5	:	Terms of Reference	22
SECTION 6	:	General Conditions of Contract	27
ANNEXURE 1:		Format of bank Guarantee for Bid security	37

## Section 1. Letter of Invitation

New Delhi

Date: April .., 2020

### 1. Introduction

The Model Solar Power Project at Neemrana, Rajasthan was a unique initiative of the Delhi - Mumbai Industrial Corridor Development Corporation Limited and was the First Smart off-grid Micro - Grid Project in the country demonstrating the concept of integration of Solar Power with industrial Diesel Generator sets. After successful operation it has been decided to discontinue the power supply to Mikuni India Pvt Ltd and install and recommission the 1 MW solar plant as a grid-connected plant for solar power supply to Toyoda Gosei Minda India Pvt Ltd on third Party sale under 2019 solar policy of Government of Rajasthan.

Therefore, DMICDC Neemrana Solar Power Company Limited (DMICDC - NSPCL) (Client) invites bids to undertake the EPC Works related to the above activities.

The detailed scope of services is provided under the Terms of Reference.

### 2. Objectives

The main objective of this RFQ cum RFP is to engage a qualified and experienced solar power project installer to act as a turnkey contractor and carry out all works related to the decommissioning of the 1 MW Solar Diesel hybrid power supply to Mikuni India Pvt Ltd, checking and servicing of all components (excluding inverters) of the 1 MW solar plant, installation of RMU, reconnecting and commissioning of the 1 MW solar plant as a grid connected plant for third party supply of solar power to Toyoda Gosei Minda India Pvt Ltd. **A Bidder as Turnkey Contractor will be selected based on qualification, experience in carrying out similar works and bid price.**

### 3. The RFQ cum RFP includes the following documents:

SECTION 1: Letter of Invitation  
SECTION 2: Instructions to Bidders  
SECTION 3: Qualification & Technical Bid - Standard Forms  
SECTION 4: Financial Bid - Standard forms  
SECTION 5: Terms of Reference  
SECTION 6 : Standard Terms of Contract  
SECTION 7 : Appendix.

Yours sincerely,

Managing Director

**DMICDC - Neemrana Solar Power Company Limited**

## Section 2. Instructions to Bidders

### 2.1 Definitions

“Applicable Laws” means all laws, brought into force and effect by GOI or the State Governments of various States, including rules, regulations and notifications made thereunder, and judgements, decrees, injunctions, writs and orders of any court of record, applicable to this Contract and the exercise, performance and discharge of the respective rights and obligations of the parties hereunder, as may be in force and effect during the subsistence of this Contract.

“**Approved / Approval**” shall mean and include approved/approval accorded by the Project Manager in writing with the concurrence of the Architect or of the Owner.

“**Associate**” shall mean a person who controls, is controlled by, or is under the common control with such Bidder.

“**Bid**” shall mean the Qualification Bid, Technical Bid and Financial Bid submitted by the Bidder, in response to Request for Qualification (RFQ) cum Request for Proposal (RFP).

“**Bidder**” shall mean Bidding Company or a Bidding Consortium (formed through a memorandum of understanding) or any other person submitting the Bid. Any reference to the Bidder includes Bidding Company / Bidding Consortium / Member of a Bidding Consortium includes its successors, executors and permitted assigns and Lead Member of the Bidding Consortium jointly and severally, as the context may be.

“**Bidding Company**” shall mean a Company incorporated in India or outside India having its office in India, that has submitted the response in accordance with the provisions of this RFQ cum RFP;

“**Client**” shall mean DMICDC Neemrana Solar Power Company Limited (DMICDC - NSPCL).

“**Company**” shall mean a body corporate defined as company and incorporated in India under the Companies Act, 1956 or Companies Act, 2013 or any other applicable statute.

“**Commissioning**” **As per the guideline issued by MNRE/ competent authority**

“**Contract**” shall mean the agreement signed between successful / selected Bidder and the Client towards successful decommissioning & commissioning of 1.00 MW Solar Power Project at Neemrana.

“**Contractor**” shall mean the Company / Selected Bidder who is responsible for all EPC works related to decommissioning of 1 MW Solar-diesel Hybrid power supply to Mikuni India Pvt Ltd and re-installing and recommissioning as grid connect solar plant for power supply to Toyoda Gosei Minda India Pvt Ltd. at Neemrana Industrial Park, Japanese Zone, Rajasthan.

“**Fraudulent Practice**” means a misrepresentation or omission of facts or disclosure of incomplete facts or intentional use of deceit, a trick or some dishonest means to influence the Selection Process;

“**JVVNL**” shall mean Jaipur Vidyut Vitran Nigam Limited.

“**Letter of Award**” or “**LoA**” shall mean a letter issued by DMICDC Neemrana Solar Power Company Limited to the selected Bidder for the award of the EPC Works Contract.

“**RRVNL**” shall mean Rajasthan Rajya Vidyut Prasaran Nigam Limited.

“**Selected Bidder / Successful Bidder**” shall mean the Bidder selected pursuant to this RFQ cum RFP to execute the EPC Works as detailed under scope of work.

“**Selection Process**” shall mean the whole process of selection of Contractor, which includes the single stage bidding process and all other relevant work as per RFQ cum RFP.

“**Similar Work**” shall mean to have carried out installation and commissioning work in at least 1 grid connected solar project of 1 MW and above at 11 KV voltage level.

“**Terms of Reference or TOR**” shall mean the scope of work towards All EPC Works ( Civil, Electrical & Mechanical), related to decommissioning of power supply to Mikuni India Pvt Ltd and installation and commissioning of solar power supply to Toyoda Gosei Minda India Pvt Ltd. as specified in Section 5.

## **2.2 Introduction**

- 2.2.1** The Client will select a Bidder, in accordance with the method of selection specified in this document. Bidders are advised that the selection of Contractor shall be on the basis of an evaluation by Client through the selection process specified in this RFQ cum RFP. Bidders shall be deemed to have understood and agreed that no explanation or justification for any aspect of the Selection Process will be given and that **DMICDC - NSPCL’s decisions are without any right of appeal whatsoever.**
- 2.2.2** The Bidders are invited to submit Qualification, Technical and Financial Bids (collectively called as “the Bid”), for all the Works required for the project. The Contractor shall be responsible to carry out the works as detailed under Terms of Reference.
- 2.2.3** The Bidder shall submit the Bid in the form and manner specified in this RFQ cum RFP. The Bid shall be submitted as per the forms given in relevant sections herewith.
- 2.2.4** Bidders should familiarize themselves with local Plant conditions at all locations ( Solar Plant, Mikuni India & Toyoda Gosei Minda ) and take them into account in preparing their Bids.
- 2.2.5** The Client will timely provide, at no cost to the Bidder, the inputs and facilities required to carry out the services, and provide relevant project data and reports related to the Project available with the Client. However, for avoidance of doubt, it is hereby clarified that the aforesaid data / information provided under the RFQ cum RFP or to be provided later, is only indicative and solely for the purposes of rendering assistance to the Bidders towards preparation of their Bids. The Bidders are hereby advised to undertake their own due diligence (to their complete satisfaction) before placing reliance on any such data / information furnished or to be provided later by the Client.
- 2.2.6** Bidders shall bear all costs associated with the preparation and submission of their bids, and their participation in the Selection Process, and presentation including but not



limited to postage, delivery fees, expenses associated with any demonstrations or presentations which may be required by Client or any other costs incurred in connection with or relating to its Bid. The Client is not bound to accept any Bid, and reserves the right to annul the selection process at any time prior to Contract award, without thereby incurring any liability to the Bidders.

2.2.7 The Bid shall be valid for a period of not less than 30 (Thirty) days from the Bid Due Date (BDD).

2.2.8 **Brief Description of the Selection Process:** The Client has adopted two envelope bidding process for evaluating the bids comprising Request for Qualification (RFQ) which includes Qualification Requirement & Request for Proposal (RFP) includes Financial bid includes final & firm quoted price.

2.2.9 Visit to the Client and Verification of Information: Bidders are encouraged to submit their respective Bids after visiting the plant / office of the Client or its delegates as the case may be, and ascertaining for themselves the availability of documents and other data with the Client, Applicable Laws and Regulations or any other matter considered relevant by them.

2.2.10 Right to reject any or all Bids:

1. Notwithstanding anything contained in this RFQ cum RFP, the Client reserves the right to accept or reject any Bid and to annul the Selection Process and reject all Bids, at any time without any liability or any obligation for such acceptance, rejection or annulment, and without assigning any reasons thereof.
2. Without prejudice to the generality of above, the Client reserves the right to reject any Bid if:
  - a) at any time, any misrepresentation is made or discovered, or
  - b) the Bidder does not provide, within the time specified by the Client, the supplemental information sought by the Client for evaluation of the Bid.
3. Such misrepresentation / improper response by the Bidder may lead to the disqualification of the Bidder. If such disqualification / rejection occurs after the Bids have been opened and the highest ranking Bidder gets disqualified / rejected, then the Client reserves the right to consider the next best Bidder, or take any other measure as may be deemed fit in the sole discretion of the Client, including annulment of the Selection Process.

2.2.11 Acknowledgement by the Bidder

1. It shall be deemed that by submitting the Bid, the Bidder has:
  - a) made a complete and careful examination of the RFQ cum RFP;
  - b) received all relevant information requested from the Client;
  - c) accepted the risk of inadequacy, error or mistake in the information provided in the RFQ cum RFP or furnished by or on behalf of the Client;
  - d) satisfied itself about all matters, things and information, including matters herein above, necessary and required for submitting an informed bid and performance of all of its obligations there under;
  - e) acknowledged that it does not have a Conflict of Interest; and
  - f) Agreed to be bound by the undertaking provided by it under and in term hereof.
2. The Client and/ or its advisors/ consultants shall not be liable for any omission, mistake or error on the part of the Bidder in respect of any of the above or on account of any matter or thing arising out of or concerning or relating to RFQ cum

RFP or the Selection Process, including any error or mistake therein or in any information or data given by the Client and/ or its consultant.

## **2.3 Clarification and amendment of RFQ cum RFP documents**

- 2.3.1 Bidders / EPCs may seek clarification on this RFQ cum RFP document, within 5 days of the date of issue of this RFQ cum RFP document. Any request for clarification must be sent by standard electronic means (PDF and word file) / fax to the Client's office addressed to:

**Managing Director,**  
**DMICDC Neemrana Solar Power Company Limited,**  
8<sup>th</sup> Floor, Jeevan Bharti Building, Tower-1,  
Connaught Place, New Delhi-110001  
Kind Att'n : Mahesh Soni  
Email address: [mahesh.dmic@gmail.com](mailto:mahesh.dmic@gmail.com)

## **2.4 Qualification Criteria:**

The Bidder shall meet the following qualification criteria to qualify the Technical Bid, as stipulated below:

### **TECHNICAL REQUIREMENTS:**

The Bidder shall be an experienced solar power plant installer and should have carried out installation and commissioning work in at least 1 grid connected solar project of 1 MW and above at 11 KV voltage level. All HT Electrical Works detailed in the Scope of Work shall be carried out by the Bidder holding a valid Class-A license. In case the bidder himself does not possess a valid Class A Electrical contracting license; he shall engage a qualified contractor with a valid Class A Electrical License. Bidder shall furnish the details of project executed such as (i) Project location & details of work carried out (ii) Customer details (iii) Valid Class-A Electrical License of the Bidder/sub-contractor.

### **FINANCIAL REQUIREMENTS:**

- a) The Bidder shall have executed solar power plant works with an average turn-over as detailed below in last 7 years:
  - i) 3 similar completed works costing more than or amount equal to 40% of the estimated cost. **OR**
  - ii) 2 similar completed works costing more than or amount equal to 50% of the estimated cost. **OR**
  - iii) 1 similar completed works costing to more than or amount equal to 80% of the estimated cost.
- b) Proof of average annual financial turnover of firm during last 3 years ending 31<sup>st</sup> March 2020 (i.e. 2017-18, 2018-19 & 2019-20) equal or more than 30% of the estimated cost.
- c) Copy of PAN & GST

- d) Bid Security Fees (EMD) (Refundable) of Rs. 30,000/- and Bid Processing Fees (Non-Refundable) of Rs.1180/- (Rs. 1000/- + 18% GST) are to be submitted through Pay Order/Demand Draft drawn on **DMICDC Neemrana Solar Power Company Limited** payable at New Delhi. Please do not use any abbreviation in the demand draft.

No interest will be payable on EMD. In the case of successful bidder, earnest money deposit will be adjusted towards the security deposit or it may be forfeited in case the successful bidder refuses to accept the award of supply or fails to complete the required formalities within the specified and permitted time. The earnest money is refundable to the unsuccessful bidders only after the finalization of the tender. The tender without EMD will be summarily rejected.

#### CHECKLIST FOR TECHNICAL BID:

S. No.	Check List for submission of Technical Documents	Attached	
		Yes	No
1	Tender Documents Duly Signed & Stamped		
2	Required EMD as applicable Rs. 30,000/-		
3	Tender Fee Rs.1180/- (Rs. 1000/- + 18% GST) (non-refundable)	.	
4	Proof of average annual financial turnover of firm during last 3 years ending 31st March 2020 (i.e. 2017-18, 2018-19 & 2019-20) equal or more than 30%of the estimated cost.		
5	Proof of having successfully completed similar works during last 7 years ending last days of the month before one in which tenders are invited as per following.		
	a. 3 similar completed works costing more than or amount equal to 40% of the estimated cost. OR		
	b. 2 similar completed works costing more than or amount equal to 50% of the estimated cost. OR		
	c. 1 similar completed works costing to more than or amount equal to 80% of the estimated cost. OR		
6	Copy of PAN & GST		
7	Copies of Similar work executed in last 3 years along with work order issued by the clients		

## **2.5 Preparation and Submission of Bid**

### **2.5.1 Language**

The Bid and all related correspondence and documents in relation to the Bidding Process shall be in English language. Supporting documents and printed literature furnished by the Bidder with the Bid may be in any other language provided that they are accompanied by appropriate translations of the pertinent passages in the English language. Supporting materials, which are not translated into English, may not be considered. For the purpose of interpretation and evaluation of the Bid, the English translation shall prevail.

### **2.5.2 Bid Preparation**

- i The Bidder shall provide all the information sought under this RFQ cum RFP in two separate envelopes. The Client will evaluate the RFQ first and only those bids that are received in the required formats and complete in all respects shall be considered for RFP. Incomplete and / or conditional bids shall be liable for rejection.
- ii The Bidder shall prepare one original set of the documents comprising the Bid (together with originals / copies of documents required to be submitted along therewith pursuant to this RFQ cum RFP) and clearly marked "ORIGINAL".
- iii RFP document of only the qualified bidders shall be opened.
- iv The Bid and its copies shall be typed or written in indelible ink and signed by the authorised signatory of the Bidder who shall also initial each page in blue ink. All the alterations, omissions, additions, or any other amendments made to the bid shall be initialled by the person(s) signing the Bid.

## **2.6 Bid Evaluation**

Prior to evaluation of Bids, the Client will determine whether each Bid is responsive to the requirements of the RFQ cum RFP . The Client may, in its sole discretion, reject any Bid that is not responsive hereunder. A Bid will be considered responsive at each stage only if:

### **RFQ**

1. The Qualification Bid is received in the form specified in this RFQ cum RFP;
2. It is received by the Bid Due Date including any extension thereof in terms hereof;
3. It is accompanied by the following documents:
  - i) Valid Class A Electrical Contracting Licence
  - ii) Details of grid connect solar projects installed and commissioned.
  - iii) Audited Turn-over in the last 3 years.
  - iv) EMD for Rs 30,000 as per 2.4 ( d)
  - v) Processing Fee of Rs 1180 as per 2.4 (d)

## RFP

### Financial Bid:

1. The Financial Bid is received in the form specified in this RFQ cum RFP
2. It is received by the Bid Due Date including any extension thereof in terms hereof;
3. It does not contain any condition or qualification

The DMICDC Neemrana Solar Power Company Limited reserves the right to reject any Bid which is non-responsive and no request for alteration, modification, substitution or withdrawal will be entertained by the Client in respect of such Bids. However, client reserves the right to seek clarifications or additional information from the Bidder during the evaluation process. The Client will subsequently examine and evaluate Bids in accordance with the Selection Process detailed out below.

#### **2.6.1 Bid Evaluation Criteria and Comparison of Bids:**

- i The DMICDC Neemrana Solar Power Company Limited will examine the bid to determine whether they are complete, whether any computational errors have been made, whether the documents have been properly signed and whether the bid is generally in order.
- ii Arithmetical errors will be rectified on the following basis. If there is discrepancy between word and figures, the amount in word will prevail. If the bidder/s do not accept the correction of the errors, such bids will be rejected.
- iii DMICDC Neemrana Solar Power Company Limited will award Contract to the successful bidder whose bid has been determined to be the lowest evaluated bid after all correction / loading, if any. **The bid shall be evaluated based on the total price quoted for executing both Part A & Part B detailed in the scope of works.**

#### **2.7 Award of Contract**

- 2.7.1 After selection, a Letter of Award (the "LOA") will be issued, in duplicate, by DMICDC Neemrana Solar Power Company Limited to the Successful Bidder.

#### **2.7.2 Execution of Contract:**

After acknowledgement of the LOA, the bidder shall commence the activities after obtaining Notice to Proceed ( NTP) from DMICDC-NSPCL.

#### **2.7.3 Commencement of Assignment:**

The Successful Bidder is expected to commence the Project as soon as the NTP is issued and acknowledged. NTP shall be issued upon the Contractor furnishing: a)Performance Security Bond b) Letter of acceptance, accepting all conditions c) signed copies of bid documents.

#### **2.8 Confidentiality**

Information relating to evaluation of Bids and recommendations concerning awards of contract shall not be disclosed to the bidders who submitted the Bids or to other persons

not officially concerned with the process, until the winning firm has been notified that it has been awarded the contract.

## **2.9 Miscellaneous**

- 2.9.1 The Selection Process shall be governed by, and construed in accordance with, the laws of India and the Courts at New Delhi shall have exclusive jurisdiction over all disputes arising under, pursuant to and/or in connection with the Selection Process and for all disputes and differences whatsoever, which shall at any time hereafter arise between the Parties hereto, touching or concerning this Agreement or its interpretation or effect or to the rights, duties, obligations and liabilities of the Parties hereto or either of them under of by virtue of this Agreement or otherwise as to any other matter in any way connected with or arising out of or in relation to the subject matter of this Agreement, Courts at New Delhi shall have exclusive jurisdiction.
- 2.9.2 DMICDC Neemrana Solar Power Company Limited, in its sole discretion and without incurring any obligation or liability, reserves the right, at any time, to:
1. suspend and/or cancel the Selection Process and/or amend and/or supplement the Selection Process or modify the dates or other terms and conditions relating thereto;
  2. consult with any Bidder in order to receive clarification or further information;
  3. retain any information and/or evidence submitted to the Client by, on behalf of and/or in relation to any Bidder; and/or
  4. Independently verify, disqualify, reject and/or accept any and all submissions or other information and/or evidence submitted by or on behalf of any Bidder.
- 2.9.3 It shall be deemed that by submitting the Bid, the Bidder agrees and releases DMICDC Neemrana Solar Power Company Limited its employees, agents and advisers, irrevocably, unconditionally, fully and finally from any and all liability for claims, losses, damages, costs, expenses or liabilities in any way related to or arising from the exercise of any rights and/or performance of any obligations hereunder, pursuant hereto and/or in connection herewith and waives any and all rights and/ or claims it may have in this respect, whether actual or contingent, whether present or future.
- 2.9.4 All documents and other information provided by DMICDC Neemrana Solar Power Company Limited or submitted by the Bidder to DMICDC Neemrana Solar Power Company Limited shall remain or become the property of Client. Bidders to treat all information as strictly confidential. DMICDC Neemrana Solar Power Company Limited will not return any Bid or any information related thereto. All information collected, analysed, processed or in whatever manner provided by the EPC Contractor to DMICDC Neemrana Solar Power Company Limited in relation to the EPC services shall be the property of Client.
- 2.9.5 DMICDC Neemrana Solar Power Company Limited reserves the right to make inquiries with any of the clients listed by the Bidders in their previous experience record.

### **Section 3. Qualification and Technical Requirements of Bid – Standard Forms**

- Form 3A: Technical Requirements Bid Submission Form
- Form 3B: Format for Technical Requirements Bid (Eligible Projects)
- Form 3C: Bidder's Experience

### 3.1 Form 3A: Technical Requirements Bid Submission Form

(To be submitted on the Letter head of the Bidder )

[Location, Date]

To,

Managing Director  
**DMICDC Neemrana Solar Power Company Limited,**  
8<sup>th</sup> Floor, Jeevan Bharti Building, Tower-1,  
Connaught Place, New Delhi-110001

**RFQ cum RFP dated [Date] for selection of Contractor for EPC works related to decommissioning of 1 MW solar-diesel off-grid power supply to Mikuni-india pvt ltd & Installation and Commissioning of 1 MW solar for third party sale to Toyoda Gosei Minda india Pvt Ltd**

---

Dear Sir,

With reference to your RFQ cum RFP Document dated [date], we, having examined all relevant documents and understood their contents, hereby submit our Qualification Bid for selection as [name of project]. The Bid is unconditional and unqualified.

We are submitting our Bid as *sole bidder*.

We understand you are not bound to accept any Bid you receive.

Further:

1. We acknowledge that DMICDC Neemrana Solar Power Company Limited will be relying on the information provided in the Bid and the documents accompanying the Bid for selection of the EPC Contractor, and we certify that all information provided in the Bid and in the supporting documents are true and correct, nothing has been omitted which renders such information misleading; and all documents accompanying such Bid are true copies of their respective originals.
2. This statement is made for the express purpose of appointment as the EPC contractor for the aforesaid Project.
3. We shall make available to DMICDC Neemrana Solar Power Company Limited any additional information it may deem necessary or require for supplementing or authenticating the Bid.
4. We acknowledge the right of DMICDC Neemrana Solar Power Company Limited to reject our application without assigning any reason or otherwise and hereby waive our right to challenge the same on any account whatsoever.
5. We declare that:
  - a) We have examined and have no reservations to the RFQ cum RFP, including any Addendum issued by DMICDC Neemrana Solar Power Company Limited;



- b) We do not have any conflict of interest in accordance with the terms of the RFQ cum RFP;
  - c) We have not directly or indirectly or through an agent engaged or indulged in any corrupt practice, fraudulent practice, coercive practice, undesirable practice or restrictive practice, as defined in the RFQ cum RFP document, in respect of any tender or request for proposal issued by or any agreement entered into with DMICDC or any other public sector enterprise or any government, Central or State; and
  - d) We hereby certify that we have taken steps to ensure that no person acting for us or on our behalf will engage in any corrupt practice, fraudulent practice, coercive practice, undesirable practice or restrictive practice.
6. We understand that you may cancel the selection process at any time and that you are neither bound to accept any Bid that you may receive nor to select the Contractor, without incurring any liability to the Bidders.
  7. We certify that in regard to matters other than security and integrity of the country, we or any of our affiliates have not been convicted by a court of law or indicted or adverse orders passed by a regulatory authority which would cast a doubt on our ability to undertake the works for the Project or which relates to a grave offence that outrages the moral sense of the community.
  8. We further certify that in regard to matters relating to security and integrity of the country, we have not been charge-sheeted by any agency of the Government or convicted by a court of law for any offence committed by us or by any of our affiliates. We further certify that neither we nor any of our consortium members have been barred by the central government, any state government, a statutory body or any public sector undertaking, as the case may be, from participating in any project or bid, and that any such bar, if any, does not subsist as on the date of this RFQ cum RFP.
  9. We further certify that no investigation by a regulatory authority is pending either against us or against our affiliates or against our CEO or any of our Directors / Managers / employees.
  10. We hereby irrevocably waive any right or remedy which we may have at any stage at law or howsoever otherwise arising to challenge or question any decision taken by DMICDC Neemrana Solar Power Company Limited in connection with the selection of Electrical contractor or in connection with the selection process itself in respect of the above mentioned Project.
  11. We agree and understand that the bid is subject to the provisions of the RFQ cum RFP document. In no case, shall we have any claim or right of whatsoever nature if the EPC for the Project is not awarded to us or our proposal is not opened or rejected.
  12. We agree to keep this offer valid for Thirty (30) days from the Bidding Date (BDD) specified in the RFQ cum RFP.
  13. We have studied RFQ cum RFP and all other documents carefully. We understand that except to the extent as expressly set forth in the Contract, we shall have no claim, right or title arising out of any documents or information provided to us by DMICDC Neemrana Solar Power Company Limited or in respect of any matter arising out of or concerning or relating to the selection process including the award of EPC contract.

14. We agree and undertake to abide by all the terms and conditions of the RFQ cum RFP Document.

We remain,

Yours sincerely,

Authorized Signature *[In full and initials]:*

Name and Title of Signatory:

Name of Organisation:

Address:

*(Name and seal of the Applicant/Member in Charge)*

### 3.2 Form 3B: Format for Technical Requirements of Bid : Eligible Projects

*(To be submitted on the Letter head of the Bidder / Lead Member of the Consortium)*

#### **Project Specific Experience**

[Using the format below, provide information on each project for which your firm was legally contracted for carrying out Works and services similar to the ones requested under this project]

Project Name and project cost:	Approx. value of the contract (INR in Lakhs):
Country: Location within country:	Duration of project (months):
Name of Client:	Total no. of staff-months of the project:
Address:	Approx. value of the services provided by your firm under the contract (in INR in Lakhs):
Start Date (Month/Year): Completion Date (Month/Year):	No. of professional staff – months provided by associated entities:
Narrative Description of Project: (highlight project Capacity in the narration)	
Description of actual services provided by your staff within the project:	
Attach Audited Turn-over of the Company in 2017-18 & 2018-19	
Attach Copy of the valid Class-A Electrical License of the agency executing the HT works.	

Firm's Name:

Authorized Signature:

## Section 4. Financial Proposal – Standard Forms

Form 4A: Financial Proposal Submission Form

### Form 4A: Financial Proposal Submission Form

*[Location]*

*[Date]*

To,

**Managing Director,**

DMICDC Neemrana Solar Power Company Limited,  
8<sup>th</sup> Floor, Jeevan Bharti Building, Tower-1,  
Connaught Place, New Delhi-110001

Dear Sir,

**Subject: Financial Bid for EPC Works *[name of project]*.**

We, the undersigned, offer to provide the EPC works as per Detailed Scope of Work for *[name of project]* in accordance with your Request for Qualification cum Request for Proposal dated *[date]* and our Proposal. We are pleased to submit our financial bid as per the **Form 4B**

Our Financial bid shall be binding upon us subject to the modifications resulting from arithmetic correction, if any, up to expiration of the validity period of the bid, i.e. *[date]*.

We undertake that, in competing for (and, if the award is made to us, in executing) the above contract, we will strictly observe the laws against fraud and corruption in force in India namely "Prevention of Corruption Act 1988".

We understand you are not bound to accept any bid you receive.

We remain,

Yours sincerely,

Authorized Signature *[In full and initials]:*

Name and Title of Signatory:

Name of Firm:

Address:

**Form 4B: Cost of EPC Works**

Sr. No.	ITEMS	AMOUNT (In Rupees)
<b>1.00 MW Solar Power Plant</b>		
1	<i>All EPC Works related to Decommissioning of solar diesel power supply to Mikuni India, installation and commissioning of 1 MW solar power plant as grid connect project for power supply to Toyoda Gosei as per scope mentioned under detailed scope of services- Part A</i>	
	<b>Total Cost of all works as per detailed scope of services Part A</b>	
	<b>2. Cost of Works related to Part-B. Client reserves the right to ask the Contractor to execute / delete this part of work.</b>	

**Note:**

1. The Price quoted by the Contractor should be in Indian Currency Only.
2. The entire price quoted should include Cost towards Insurance, All Applicable State and Central Taxes and Duties etc.
3. The client will not reimburse any other amount over and above quoted by bidder.
4. Payment shall be made as per billing schedule mentioned under Payment terms.

## Section 5. Terms of Reference

### 5.1. SITE DESCRIPTION

#### 5.1.1 LOCATION

- The 1 MW plant is located in Neemrana Industrial Park, Japanese Zone, Neemrana, Dist: Alwar, Rajasthan, India.

Neemrana Industrial Area,  
Japanese Zone, Neemrana

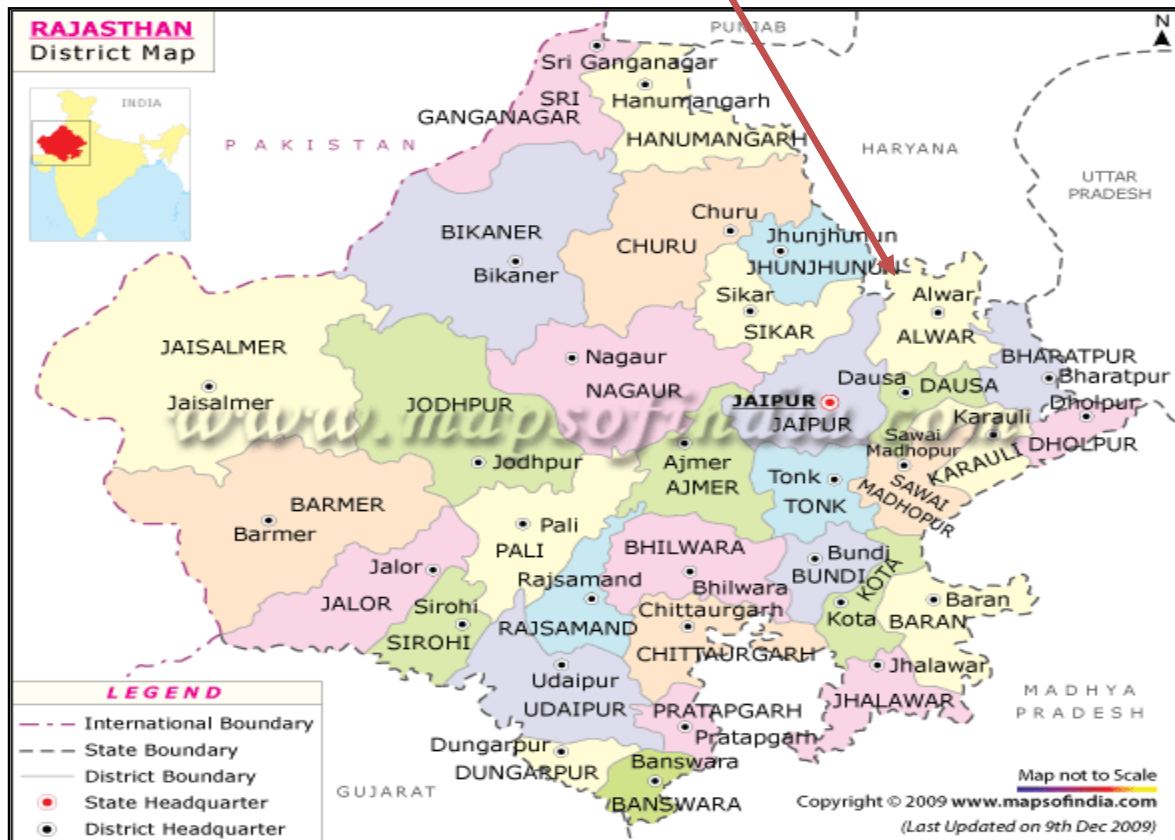

Figure 1: Rajasthan State Map



**LOCATION MAP OF DNSPCL PLANT, TOYODA GOSEI MINDA PLANT & MIKUNI INDIA PLANT**

The above satellite image shows the location of all the 3 plants, 1 MW Solar Plant, Toyoda Gosei Minda India Plant adjacent to the 1 MW Solar Plant, and Mikuni India Plant located about 700 Meters from the Solar Plant.

ABCDEFG is the route of the 2 Nos of 11 KV Underground cable presently from the Solar Plant to Mikuni India.

DNSPCL plan is to Splice the cable at Point D and route the same to the HT breaker room as shown in image below.



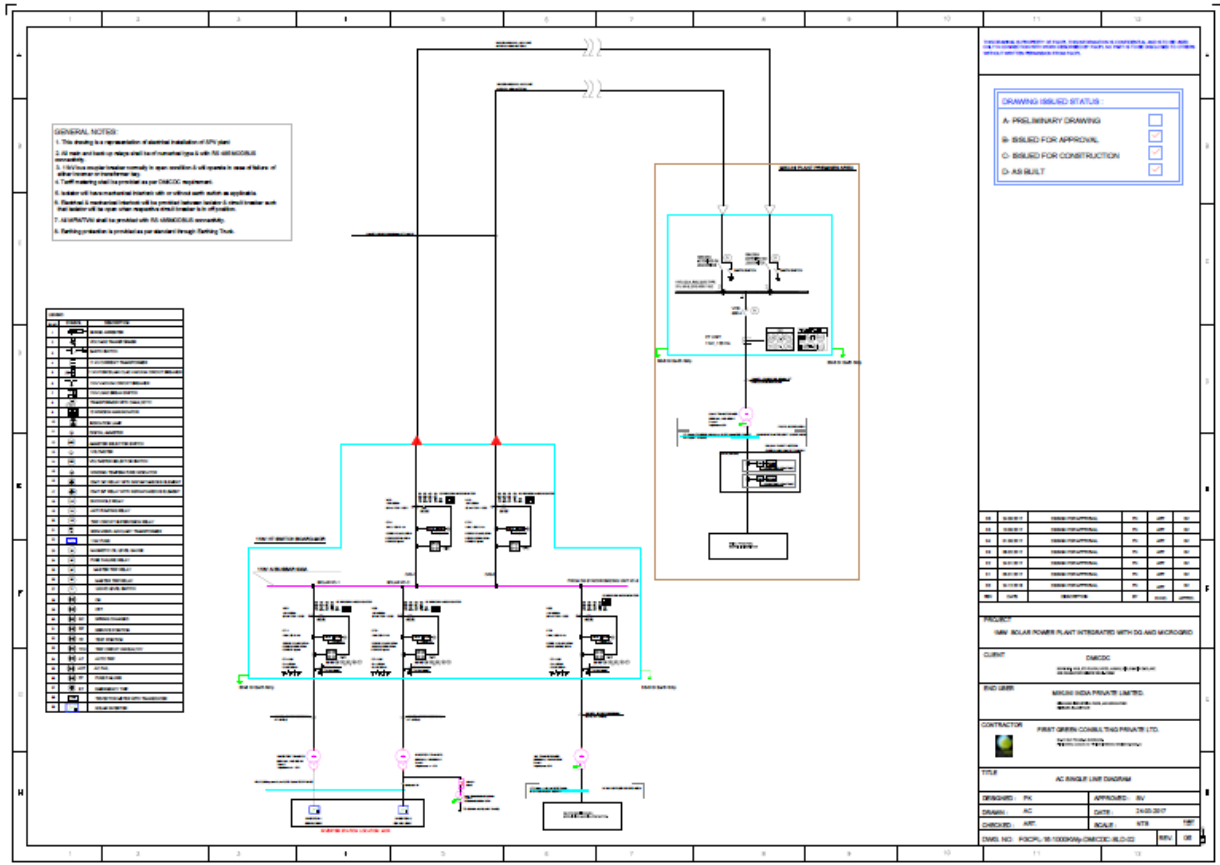

SLD of existing 1 MW Solar Plant



## 5.2 DETAILED SCOPE OF SERVICES:

### PART-A

Services related to Mikuni India decommissioning activities :

#### AT MIKUNI PLANT :

1. Dismantling of 11 KV HT cable from RMU to Transformer and both side HT kit and LT connection on transformer outgoing side and breaker of Mikuni. Dismantling of RMU and shifting to Toyoda Gosei Minda India Ltd and reinstallation at Toyoda Gosei.
2. Dismantling of Transformer with RTCC Panel and OLTC control cable and transporting them to 1 MW solar plant.

#### AT 1 MW SOLAR PLANT :

1. Removal of the 2.5 MVA transformer and reinstallation of the 1.5 MVA transformer ( shifted from Mikuni ) in its place. Existing Foundation of the 2.5 MVA transformer to be suitably modified for the 1.5 MVA transformer.
2. Disconnect the interconnecting cable between DG panel and LT panel at the DG panel end and reconnect to the LV side of the 1.5 MVA transformer.
3. 2 Nos of Inverter Transformer & 1 No 1.5 MVA Transformer servicing with Oil Dehydration and Silica Gel replacement and input output terminal servicing and relevant testing before being put into service . If OEM personnel is engaged, Contractor shall supervise and ensure quality of work. Bidder / OEM is expected to anticipate and provide for the normal maintenance spares that may be required while servicing of the transformers and include the same in the contract price.
4. Checking of DC system from solar panel to inverter and ensure integrity.
5. Checking of HT breakers, servicing & replacement of degraded components. If OEM of breaker is engaged for the same, the Contractor shall supervise and ensure quality of work. , Bidder / OEM is advised to visit the solar plant to inspect the HT breakers and make an assessment of the spares that would be needed for replacement and include the same in the contract price.
6. Protection Checking, Testing and commissioning of all systems as on Grid connect systems.

#### AT TOYODA GOSEI MINDA INDIA PLANT :

1. The two 11 KV underground cable running from 1 MW Solar Plant to Mikuni India plant is to be rerouted to the Toyoda Gosei 11 KV breaker room by splicing the cable at about 5-10 metres ( Point D ) from the Toyoda Gosei breaker room ( as shown in the satellite image above) including required trenching / civil works.
2. Checking and Servicing of the RMU ( removed from Mikuni Plant and installed at Toyoda) inside 11KV HT breaker room of Toyoda Gosei .
3. Termination of both the 11 KV HT cable in the RMU.
4. Supply & Installation of the 11 KV HT MIP Meter box as per JVVNL norms.
5. 11 KV CT / PT as per JVVNL Norms with CTL tested with control wiring complete.
6. Interconnection between RMU, Meter box and breaker of Toyoda Gosei.
7. All civil and mechanical works related to the cable, meter box installation.
8. Preparation and approval ( by relevant agencies) of all drawings related to civil, mechanical and electrical works
9. CEIG approval for the interconnection to Toyoda Gosei & coordination / approval of JVVNL

## **PART- B**

1. **Removal of the two buried cable from the spliced point D near Toyoda Gosei going to Mikuni India and transporting the recovered cable to the 1 MW plant including all civil works of digging and finishing the trench after cable removal.**

**Bidder is expected to submit the financial offer for this activity as a standalone activity and DNSPCL reserves the right to ask the successful contractor to either execute the same or defer this activity.**

### **NOTE :**

**Bidder shall be responsible for obtaining clearance from RIICO if required for trench digging, right of way etc.DNSPCL shall extend any support required .**

**5.3 ESTIMATED TENDER VALUE : Rs 15 Lakhs ( Rupees Fifteen Lakhs)**

## **6.0 GENERAL CONDITIONS OF CONTRACT**

### **6.1 OBLIGATIONS OF THE CONTRACTOR:**

#### **6.1.1 General obligations:**

Subject to and on the terms and conditions of this Agreement, the Contractor shall undertake the survey, investigation, arrange parts, components, tools and tackles, labour & sub-contractor as may be required for carrying out the scope of work mentioned in this document.

The Contractor shall comply with all applicable laws in the performance of its obligations under this Agreement.

the Contractor shall discharge its obligations in accordance with Good Industry Practice and as a reasonable and prudent person.

The Contractor shall remedy without any additional cost, any defects associated with the scope of work undertaken by the contractor during the defect liability period of 3 months, except to the extent that any such loss or damage shall have arisen on account of any or on account of a Force Majeure Event.

The Contractor shall undertake all necessary superintendence to plan, arrange, direct, manage, inspect and test the Works of erection and commissioning as detailed under the scope.

#### **6.1.2 Electricity, Water and Other Services**

The Contractor shall be responsible for procuring of all power, water and other services that it may require.

#### **6.1.3 Obligations Relating to Sub - contracts and Any Other Agreements**

The Contractor may engage the OEMs for the servicing of the HT breaker panels and transformer. However, Contractor shall be responsible for coordination, supervision and ensuring quality of work of the OEM personnel.

#### **6.1.4 Contractor's Personnel**

The Contractor shall ensure that the personnel engaged by it or by its Subcontractors in the performance of its obligations under this Agreement are at all times appropriately qualified, skilled and experienced in their respective functions in conformity with Good Industry Practice.

#### **6.1.5 Labour and Personnel**

The Contractor shall make his own arrangements for the engagement of all staff and labour, local or otherwise, and for their payment, housing feeding and transport Contractor shall provide all labour and personnel required in connection with Work and shall be liable for all risks on account of their safety security, accidents and mis-happenings both physically and monetarily and the Contractor hereby indemnifies the

DMICDC-NSPCL for any loss and / or damages sustained by the DMICDC-NSPCL in that regard.

#### **6.1.6 Labour Laws**

The Contractor shall comply with and shall ensure that he/his Sub-contractors comply with all the relevant labour laws applicable to his Sub-contractors employees, and shall duly pay and afford and cause his Sub-contractors to pay and afford to them all their legal rights. The Contractor shall require all such employees to obey all Applicable Laws and regulations concerning safety at Work. Contractor shall be responsible for all labour relation matters relating to the Work or Supply of Goods and shall at all times use its best efforts to maintain harmony among the personnel employed in connection with the Work or supply of Goods whether by the Contractor or his Sub-contractors and shall enter into all necessary labour agreements with such personnel. Contractor and his Sub-contractors shall at all times comply with all Applicable Permits and Applicable Laws relating to employment including but not limited to Contract labour regulations, Workmen Compensation Act, Employee State Insurance and Provident Fund regulations, retrenchment Compensation etc. and labour welfare and use its best efforts and judgment as an experienced Contractor to adopt and implement policies and practices to avoid Work stoppages, slowdowns, disputes, strikes, lockouts and other labour strife and disagreement.

#### **6.1.7 Transporting ,Storage, Covering and Handling of Plant**

All the activities such as transportation, storage, covering, loading, unloading and handling etc.in carrying out the scope of work under this contract shall be in the scope of Contractor only. DMICDC-NSPCL shall not be responsible for any acts, results and effect arising thereof.

#### **6.1.8 Work and Safety Regulations**

The Contractor shall ensure proper safety of all the workmen, materials and equipments belonging to him or to DMICDC-NSPCL, working at the Site. The Contractor shall also be responsible for provision of all safety notices and safety equipment required both by the relevant legislations and the DMICDC-NSPCL, as he may deem necessary.

All equipment used in construction and erection by Contractor or his Sub contractors shall meet Indian and International Standards of safety and where such standards do not exist, the Contractor shall ensure these to be absolutely safe. All equipments shall be strictly operated and maintained by the Contractor or his Sub contractors in accordance with manufacturers operation manual and safety instructions and as per Guidelines and Rules of the DMICDC-NSPCL in this regard.

In case any accident occurs during the construction / erection or either associated activities undertaken by the Contractor thereby causing any minor, major or fatal injuries to his employees due to any reason, whatsoever, it shall be the responsibility of the Contractor to promptly inform the same to the DMICDC-NSPCL in prescribed form and also to all the authorities envisaged under the Applicable Laws.

The contractor shall follow-up the regulatory procedures with the statutory authorities till the final settlement of the accident formalities, payment of compensation to the personnel affected / injured / deceased in the accident and shall also ensure the treatment to be made available to the affected / injured personnel.

In case of failure of the contractor to complete all the relevant and legal formalities resulting out of the accident, DMICDC-NSPCL reserves the right to complete all the relevant and legal formalities including payment of the compensation amounts to the affected personnel recover the cost from the contractor.

### **6.1.9 Contractor's Insurance Obligations**

- i. The contractor shall be responsible for taking insurance cover under the Workmen's Compensation Act for the staff and labour force engaged by him for execution of the contract.
- i All accidents occurring at site during the tenure of the contract period shall be reported by the contractor to the client and relevant authorities and shall also disburse the compensation due to the personnel under the Rajasthan State Labour Act and as directed by the Department of Labour, Govt. of Rajasthan / Electrical Inspector to the Govt. of Rajasthan / Directorate of Health & Safety, Govt. of Rajasthan.
- ii In case of failure of the contractor to disburse such compensation as due to be payable to the staff / labour, the client shall have the right to disburse such compensation amounts on behalf of the contractor and recover such amounts from the claims of the contractor related to the subject contract.
- iii All insurance premiums to be paid for the insurance covers during the tenure of the contract period shall be borne by the contractor.

### **6.1.10 Payment to Subcontractor**

Contractor shall be responsible for making payments to Subcontractor and shall indemnify and hold DMICDC-NSPCL harmless against default by Contractor on making such timely payment to Subcontractor.

In case of default by the Contractor in making payment to the Subcontractor, DMICDC-NSPCL shall be entitled to deduct appropriate amounts from the payments due to be made by DMICDC-NSPCL to the Contractor.

## **6.2 OBLIGATIONS OF DMICDC-NSPCL**

### **6.2.1 Obligations of DMICDC-NSPCL**

DMICDC-NSPCL shall, at its own cost and expense, undertake, comply with and perform all its obligations set out in this Agreement or arising hereunder.

### **6.2.2 Access and Right to Use of the Site**

The DMICDC- NSPCL shall grant the Contractor right of access to, and make available the Site to the Contractor in accordance with the terms of the DMICDC-NSPCL's property rights at the time of execution of this Agreement. Such right and use of the Site may not be exclusive to the Contractor, in the execution of the Works, no persons other than the Contractor or his duly appointed authorized representative, Sub-contractor and workmen, shall be allowed to do work on the Site, except by the special permission, in writing of the DMICDC- NSPCL.

### **6.2.3 Notice to Proceed**

DMICDC-NSPCL is in the process of obtaining In-Principle Clearance from RRECL and shall issue the Notice to proceed only on or after the In-Principle Clearance is accorded by RRECL and the commencement Date shall occur only after DMICDC-NSPCL has provided Contractor the Notice to Proceed ( NTP ) which will be issued after the successful bidder furnishes a) the performance security bond b) Letter of Acceptance c) initialled copies of bid documents.

### **6.2.4 Permits and Real Estate Rights**

DMICDC-NSPCL shall obtain and maintain in effect the Real Estate Rights and obtain and maintain all Applicable Permits required in connection with the ownership and Operation and Maintenance of the Solar Power Project. Contractor shall however be responsible for obtaining CEIG / JVVNL clearance for the interconnection with Toyoda Gosei

### **6.2.5 Permit Support**

With respect to CEIG/ any other agency ( RIICO, JVVNL etc) approval of the Permits, DMICDC-NSPCL shall provide support to Contractor, which support include : (a) attendance at meetings with Contractor and third party designated by Contractor, (b) assistance in preparation of responses to inquiries by Governmental Agencies, (c) assistance in presentations at hearings of Governmental Agency, (d) provision of all non-engineering and necessary information and documents required by Statutory authority in connection with obtaining any Permits and

Except the above support, all necessary documents or requirements to secure the CEIG / any other approval shall be in the scope of contractor only.

### **6.2.6 DMICDC-NSPCL's Other Obligations**

DMICDC-NSPCL shall also obtain and maintain insurance as it may be required by them in addition to that provided by Contractor.

## **6.3 PERFORMANCE SECURITY**

### **6.3.1 Performance Security**

The Contractor shall, for the performance of its obligations hereunder during the Construction Period, provide to the DMICDC-NSPCL, within 5 (ten) days of the date of LOA, an irrevocable and unconditional guarantee from a Bank in the form set forth in **Annexure 1** (the “**Performance Security**”) for an amount equal to 10% (Ten percent) of the Contract Price. The Performance Security shall be valid till 30 (Thirty) days beyond the final acceptance testing. Until such time the Performance Security is provided by the Contractor pursuant hereto and the same comes into effect, the Bid Security shall remain in force and effect. DMICDC-NSPCL shall release the Bid Security to the Contractor once the Final Acceptance Certificate is issued

### **6.3.2 Appropriation of Performance of Security**

Upon occurrence of a Contractor’s Default, the DMICDC-NSPCL shall, without prejudice to it’s other rights and remedies hereunder or in law, be entitled to encash and appropriate the relevant amounts from the Performance Security as Damages for such Contractor’s Default.

## **6.4 COMPLETION CERTIFICATE**

### **6.4.1 Tests on Completion**

At least 3 ( Three ) days prior to the likely completion of the scope of work, the Contractor shall notify the **DMICDC-NSPCL** of its intent to subject the Solar Plant or a Part thereof, to Tests. The date and time of each of the Tests shall be determined by the **DMICDC-NSPCL** in consultation with the Contractor. Contractor shall either conduct the Tests as directed by the **DMICDC-NSPCL** or provide such assistance as the **DMICDC-NSPCL** may reasonably require for conducting the Tests.

The **DMICDC-NSPCL** shall either conduct or observe, monitor and review the Tests conducted by the Contractor, as the case may be and review the results of the Tests to determine compliance of the Solar Power Project or a part thereof, with Specifications and Standards and if it is reasonably anticipated or determined by **DMICDC-NSPCL** during the course of any Test that the performance of the Solar Power Project or any part thereof, does not meet the Specifications and Standards, it shall have the right to suspend or delay such Test and require the Contractor to remedy and rectify the Defect or deficiencies. Upon completion of each Test, the **DMICDC-NSPCL** shall provide to the Contractor, copies of all Test data including detailed Test results

### **6.4.2 Completion Certificate - Final Acceptance Certificate (FAC)**

Upon completion of all works, including the items and the **DMICDC-NSPCL** determining the Tests to be successful as per the criteria given below, it shall forthwith issue within 7 days to the Contractor, a certificate (the “**Completion Certificate - FAC**”).

### 6.4.3 PERFORMANCE ACCEPTANCE CRITERIA :

Trial operation of the plant shall be carried out over 3 days and the Performance Ratio ( PR ) shall be calculated. If the PR is in the range of 75%-80% the plant performance shall be deemed to be successful. If the PR is lower, then the cause shall be investigated and rectified.

## 6.5 CHANGE OF SCOPE

### 6.5.1 Change of Scope

The DMICDC-NSPCL may, notwithstanding anything to the contrary contained in this Agreement, require the Contractor to make modifications / alterations to the Works (“**Change of Scope**”) before the issue of the Completion Certificate either by giving an instruction or by requesting the Contractor to submit a proposal for Change of Scope involving additional cost or reduction in cost. Any such Change of Scope ( subject to a maximum of 10% of Contract Value ) shall be made and valued in accordance with the prudent industry norms.

## 6.6 PAYMENTS

### 6.6.1 Contract Price:

The Contract Price for the entire scope of Work and supplies is fixed, on lump sum basis and will remain firm throughout the Contract Period. The Contract price is not subject to any escalation and variation in price except as otherwise provided (mentioned).

Contract price agreed is Inclusive of all taxes, duties, levy etc., as per applicable rates at the time of raising the Invoice.

The Turnkey contract is a lumpsum price contract and the payments will be released on completion particular stage / deliverable.

DMICDC-NSPCL shall carry out necessary deductions on account of TDS, WCT, Labour cess etc., as per the applicable laws and rates from the bill of contractor.

### 6.6.2 Terms of Payment

The DMICDC-NSPCL shall pay the Contractor in the following manner and at the following times, on the basis of the Contract Price and Components.

All the payments will be released after completion of milestones as detailed below:

Sr. No.	Deliverables	Stage payment, %
1	On completion of works to be carried out at Mikuni	Twenty Percent (20%)
2	On Completion of works at Toyoda Gosei	Thirty Percent (30%)
3	On Completion works at 1 MW solar plant	



3a	DC system Checks	Five Percent (5%)
3b	HT Breaker servicing	Five Percent (5%)
3c	2.5 MVA Transformer removal and installation of 1.5 MVA transformer with cabling	Five Percent (5%)
3d	Servicing of 3 Transformers	Ten Percent ( 10%)
3e	Drawing ( SLD) submission & approval	Five Percent ( 5%)
4.	CEIG Clearance + commissioning	Ten Percent ( 10%)
5.	Final Acceptance	Ten Percent ( 10%)

## 6.7 FORCE MAJEURE

### 6.7.1 Force Majeure

As used in this contract, the expression “**Force Majeure**” or “**Force Majeure Event**” shall mean occurrence in India of any or all of Event, as defined below if it affects the performance by the Party claiming the benefit of Force Majeure (the “**Affected Party**”) of its obligations under this Agreement and which act or event (i) is beyond the reasonable control of the Affected Party, and (ii) the Affected Party could not have prevented or overcome by exercise of due diligence and following Good Industry Practice, and (iii) has Material Adverse Effect on the Affected Party.

A Force Majeure Event shall mean one or more of the following acts or events:

- (a) act of God, epidemic, extremely adverse weather conditions, lightning, earthquake, landslide, cyclone, flood, volcanic eruption, chemical or radioactive contamination or ionising radiation, fire or explosion (to the extent of contamination or radiation or fire or explosion originating from a source external to the Site) or any other related event;
- (b) strikes or boycotts (other than those involving the Contractor, Subcontractors or their respective employees/representatives, or attributable to any act or omission of any of them) interrupting supplies and services to the Solar Power Project for a continuous period of 24 (twenty-four) hours and an aggregate period exceeding 10 (ten) days in an Accounting Year, and not being an Indirect Political Event set forth in Clause 20.3;
- (c) any failure or delay of a Sub-contractor but only to the extent caused by another Force Majeure event
- (d) any event or circumstances of a nature analogous to any of the foregoing.
- (d) an act of war (whether declared or undeclared), invasion, armed conflict or act of foreign enemy, blockade, embargo, riot, insurrection, terrorist or military action, civil commotion or politically motivated sabotage;
- (e) industry-wide or State-wide strikes or industrial action for a continuous period of 24 (twenty-four) hours and exceeding an aggregate period of 10 (ten) days in an Accounting Year;
- (f) any civil commotion, boycott or political agitation which prevents construction of the Model Solar Power Project by the Contractor for an aggregate period exceeding 10 (ten) days in an Accounting Year;
- (g) any failure or delay of a Sub-contractor to the extent caused by any Force Majeure Event;

Upon the occurrence of any Force Majeure Event during the Contract Period, the Project Completion Schedule for and in respect of the affected Works shall be extended on a day for day basis for such period as performance of the Contractor's obligations is affected on account of the Force Majeure Event or its subsisting effects.

Neither Party shall be liable in any manner whatsoever to the other Party in respect of any loss, damage, cost, expense, claims, demands and proceedings relating to or arising out of occurrence or existence of any Force Majeure Event

## **6.8 IMPLEMENTATION SCHEDULE**

6.8.1 The Contractor shall carry out all the works as per the detailed scope of works provided in bid / tender document. The Contractor shall be responsible for the correct positioning of all parts of the Works, and shall rectify any error in the Works. The Contractor agrees and undertakes that all works shall be completed on or before the Scheduled Completion Date set forth in Appendix-1, including any extension thereof.

6.8.2 In the event, that the Contractor fails to achieve the Scheduled Completion Date within the specified days from the date, unless such failure has occurred due to Force Majeure or for reasons solely attributable to the DMICDC-NSPCL, it shall pay Damages to the DMICDC-NSPCL of a sum calculated at the rate of 0.05% (zero point zero five percent) of the Contract Price for delay of each day reckoned from the date specified; and until such Project Milestone is achieved or the Works are completed; provided that if the period for any or all Project Milestones or the Scheduled Completion Date is extended in accordance with the provisions of this Agreement, the dates shall be deemed to be modified accordingly and the provisions of this Agreement shall apply as if has been amended as above; provided further that in the event the Works are completed within or before the Scheduled Completion Date including any Time Extension, applicable for that work or section, the Damages paid under this Clause 6.8.2 shall be refunded by the DMICDC-NSPCL to the Contractor, but without any interest thereon. For the avoidance of doubt, it is agreed that recovery of Damages under this Clause shall be without prejudice to the rights of the DMICDC-NSPCL under this Agreement including the right of Termination thereof. The Parties further agree that Time Extension hereunder shall only be reckoned for and in respect of the affected works as specified in Clause 6.8.2

6.8.3 The DMICDC-NSPCL shall notify the Contractor of its decision to impose Damages in pursuance with the provisions of this Clause 6.8.2. Provided that no deduction on account of Damages shall be effected by the DMICDC-NSPCL without notifying the Contractor of its decision to impose the Damages, and taking into consideration the representation, if any, made by the Contractor within 7 (seven) days of such notice. The Parties expressly agree that the total amount of Damages under Clause 6.8.2 shall not exceed **5% (five percent)** of the Contract Price.

## **6.9 LIABILITY AND INDEMNITY**

### **6.9.1 General Indemnity**

The Contractor will indemnify, defend, save and hold harmless the DMICDC-NSPCL and its officers, servants, agents, Government Instrumentalities and Government owned and/or controlled entities / enterprises, (the "DMICDC-NSPCL **Indemnified Persons**") against any and all suits, arbitration and proceedings, actions, demands, temporary and/or mandatory injunctions and third party claims for any loss, damage, cost and expense of whatever kind and nature, whether arising out of any breach by the Contractor of any of its obligations under this contract or from any negligence under the

contract, including any errors or deficiencies in the design documents, or tort or on any other ground whatsoever, except to the extent that any such suits, proceedings, actions, demands and claims have arisen due to any negligent act or omission, or breach or default of this contract on the part of the Authority Indemnified Persons.

#### **6.10 TERMINATION UPON CONTRACTOR DEFAULT**

Upon occurrence of a Contractor Default, the DMICDC-NSPCL shall be entitled, hereunder, to terminate carrying out of the Works or any part thereof, and (ii) carry out such Works itself or authorise any other person to exercise or perform the same on its behalf. Termination hereunder shall be effective forthwith upon issue of notice by the DMICDC-NSPCL to the Contractor.

The defaults referred to herein shall include:

- (a) the Contractor fails to provide, extend or replenish, as the case may be, the Performance Security.
- (b) the Contractor does not achieve the Project completion as per schedule due in accordance with the provisions of Schedule, subject to any Time extension.
- (c) the Contractor abandons or manifests intention to abandon the construction without the prior written consent of the **DMICDC-NSPCL**;
- (d) failure to complete the Punch List items within 15 days of project completion.
- (e) the Contractor fails to rectify any Defect, the non-rectification of which shall have a Material Adverse Effect on the Project
- (f) the Contractor subcontracts the Works or any part thereof in violation of this Agreement
- (g) the Contractor creates any Encumbrance in breach of this Agreement;
- (h) the Contractor has been, or is in the process of being liquidated, dissolved, wound-up, amalgamated or reconstituted in a manner that would cause, in the reasonable opinion of the **DMICDC-NSPCL**, a Material Adverse Effect;
- (i) Any representation or warranty of the Contractor herein contained which is, as of the date hereof, found to be materially false or the Contractor is at any time hereafter found to be in breach thereof;
- (j) the Contractor submits to the DMICDC-NSPCL any statement, notice or other document, in written or electronic form, which has a material effect on the **DMICDC-NSPCL**'s rights, obligations or interests and which is false in material particulars;
- (k) the Contractor has failed to fulfil any obligation, for which failure Termination has been specified in this Agreement; or
- (l) The Contractor commits a default in complying with any other provision of this Agreement if such a default causes a Material Adverse Effect on the Project or on the **DMICDC-NSPCL**.

## Appendix -1

### Project Schedule

DMICDC Neemrana Solar Power Company Limited will endeavour to adhere to the following schedule:

Sr. No.	Description	Estimated Time D, Days	Reference from D
1.	Date of Issue of RFQ cum RFP	Zero Date (D) 20.04.2020	(D)
2.	Last date for receiving queries/requests for clarifications	D+5 25.04.2020	D + 5 (D1)
3.	Pre-bid Meeting ( Thru video conferencing in case of lockdown)	D1 + 3 28.04.2020	D + 8 (D2)
4.	Client's response to queries/requests for clarifications	D2 + 3 30.04.2020	D + 11 (D3)
5.	Bid Due Date & Opening of Envelope	D3 + 10 11.05.2020	D + 21 (D4)
6	LOA & NTP	D4 + 5 16.05.2020	D + 26 (D5)
7	Completion & Commissioning of Plant ( PART-A )	D5 + 14 30.05.2020	D + 40 (D6)
8	Trial Operation	D6 + 3 02.06.2020	D + 43(D7)
9	Scheduled Commercial Operation Date		D + 43 (D8)
10.	Completion of Part-B ( In case the option to execute is exercised by DNSPCL)	D8+7 09.06.2020	D+50

## ANNEXURE - 1

### Format of Bank Guarantee for Performance Security

BG No.

Date:

1. In consideration of you, DMICDC Neemrana Solar Power Company Limited, a company incorporated under the Companies Act, 1956 or 2013 or any other applicable statute, having its registered office at \_\_\_\_\_ (hereinafter referred to as the "Client" which expression shall, unless repugnant to the context or meaning thereof, include its administrators, successors and assigns) having agreed to receive the proposal of **[Name of company]**, a company registered under the Companies Act, 1956 or 2013 or any other applicable statute and having its registered office at *[registered address of company]*, [and acting on behalf of a Consortium comprising of *[name of company]*, *[name of company]* and *[name of company]*] (hereinafter referred to as the "Bidder" which expression shall unless it be repugnant to the subject or context thereof include its successors and assigns), for appointment as EPC Contractor for *[name of project]* (hereinafter referred to as the "EPC Contractor") pursuant to the RFQ cum RFP Document dated *[date]* issued in respect of the EPC and other related documents including without limitation the draft contract for EPC services (hereinafter collectively referred to as "RFQ cum RFP Documents"), we *[Name of the Bank]* having our registered office at *[registered address]* and one of its branches at *[branch address]* (hereinafter referred to as the "Bank"), at the request of the Bidder, do hereby in terms of relevant clause of the RFQ cum RFP Document, irrevocably, unconditionally and without reservation guarantee the due and faithful fulfilment and compliance of the terms and conditions of the RFQ cum RFP Document by the said Bidder and unconditionally and irrevocably undertake to pay forthwith to the Client an amount of Rs..... *[in figures]**([in words])* (hereinafter referred to as the "Guarantee") as our primary obligation without any demur, reservation, recourse, contest or protest and without reference to the Bidder if the Bidder shall fail to fulfil or comply with all or any of the terms and conditions contained in the said RFQ cum RFP Document.
2. Any such written demand made by the Client stating that the Bidder is in default of the due and faithful fulfilment and compliance with the terms and conditions contained in the RFQ cum RFP Document shall be final, conclusive and binding on the Bank. We, the Bank, further agree that the Client shall be the sole judge to decide as to whether the Bidder is in default of due and faithful fulfilment and compliance with the terms and conditions contained in the RFQ cum RFP Document including, Document including without limitation, failure of the said Bidder to keep its Bid valid during the validity period of the Bid as set forth in the said RFQ cum RFP Document, and the decision of the Client that the Bidder is in default as aforesaid shall be final and binding on us, notwithstanding any differences between the Client and the Bidder or any dispute pending before any court, tribunal, arbitrator or any other authority.
3. We, the Bank, do hereby unconditionally undertake to pay the amounts due and payable under this Guarantee without any demur, reservation, recourse, contest or protest and without any reference to the Bidder or any other person and irrespective of whether the claim of the Client is disputed by the Bidder or not, merely on the first demand from the Client stating that the amount claimed is due to the Client by reason of failure of the Bidder to fulfil and comply with the terms and conditions contained in the RFQ cum RFP Document including without limitation, failure of the said Bidder to keep its Proposal valid during the

validity period of the bid as set forth in the said RFQ cum RFP Document for any reason whatsoever. Any such demand made on the Bank shall be conclusive as regards amount due and payable by the Bank under this Guarantee. However, our liability under this Guarantee shall be restricted to an amount not exceeding Rs..... *[in figures] ([in words])*.

4. This Guarantee shall be irrevocable and remain in full force for a period of 180 (one hundred and eighty) days from the Bid Due Date and a further claim period of thirty (30) days or for such extended period as may be mutually agreed between the Client and the Bidder, and agreed to by the Bank, and shall continue to be enforceable until all amounts under this Guarantee have been paid.
5. The Guarantee shall not be affected by any change in the constitution or winding up of the Bidder or the Bank or any absorption, merger or amalgamation of the Bidder or the Bank with any other person.
6. In order to give full effect to this Guarantee, the Client shall be entitled to treat the Bank as the principal debtor. The Client shall have the fullest liberty without affecting in any way the liability of the Bank under this Guarantee from time to time to vary any of the terms and conditions contained in the said RFQ cum RFP Document or to extend time for submission of the Bids or the Bid validity period or the period for conveying of Letter of Acceptance to the Bidder or the period for fulfilment and compliance with all or any of the terms and conditions contained in the said RFQ cum RFP document by the said Bidder or to postpone for any time and from time to time any of the powers exercisable by it against the said Bidder and either to enforce or forbear from enforcing any of the terms and conditions contained in the said RFQ cum RFP document or the securities available to the Client, and the Bank shall not be released from its liability under these presents by any exercise by the Client of the liberty with reference to the matters aforesaid or by reason of time being given to the said Bidder or any other forbearance, act or omission on the part of the Client or any indulgence by the Client to the said Bidder or by any change in the constitution of the Client or its absorption, merger or amalgamation with any other person or any other matter or thing whatsoever which under the law relating to sureties would but for this provision have the effect of releasing the Bank from its such liability.
7. Any notice by way of request, demand or otherwise hereunder shall be sufficiently given or made if addressed to the Bank and sent by courier or by registered mail to the Bank at the address set forth herein.
8. We undertake to make the payment on receipt of your notice of claim on us addressed to *[Name of bank along with branch address]* and delivered at our above branch which shall be deemed to have been duly authorised to receive the said notice of claim.
9. It shall not be necessary for the Client to proceed against the said Bidder before proceeding against the Bank and the guarantee herein contained shall be enforceable against the Bank, notwithstanding any other security which the Client may have obtained from the said Bidder or any other person and which shall, at the time when proceedings are taken against the Bank hereunder, be outstanding or unrealised.
10. We, the Bank, further undertake not to revoke this Guarantee during its currency except with the previous express consent of the Client in writing.

11. The Bank declares that it has power to issue this Guarantee and discharge the obligations contemplated herein, the undersigned is duly authorised and has full power to execute this Guarantee for and on behalf of the Bank.
12. For the avoidance of doubt, the Bank's liability under this Guarantee shall be restricted to Rs..... *[in figures] ([in words])*. The Bank shall be liable to pay the said amount or any part thereof only if the Client serves a written claim on the Bank in accordance with paragraph 8 hereof, on or before [date].

Signed and Delivered by *[name of bank]*

By the hand of Mr. /Ms.*[name]*, it's *[designation]* and authorised official.

*(Signature of the Authorised Signatory) (Official Seal)*

**Notes:**

- The Bank Guarantee should contain the name, designation and code number of the officer(s) signing the Guarantee.
- The address, telephone number and other details of the Head Office of the Bank as well as of issuing Branch should be mentioned on the covering letter of issuing Branch.